

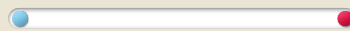

Water Cooled Units Technical Data

HWP 36, 48, 59, 79, 98, 118, 142, 172, 192, 255, 275



Cooling Capacity
3.5kW - 27.5kW

Heating Capacity
3.6kW - 24.5kW

Water Cooled air conditioners

HWP 36–275 series



The HWP units provide a choice of cooling only or reverse cycle (heat pump) packaged system air conditioners designed and developed to comply with and exceed AS/NZS 3823.

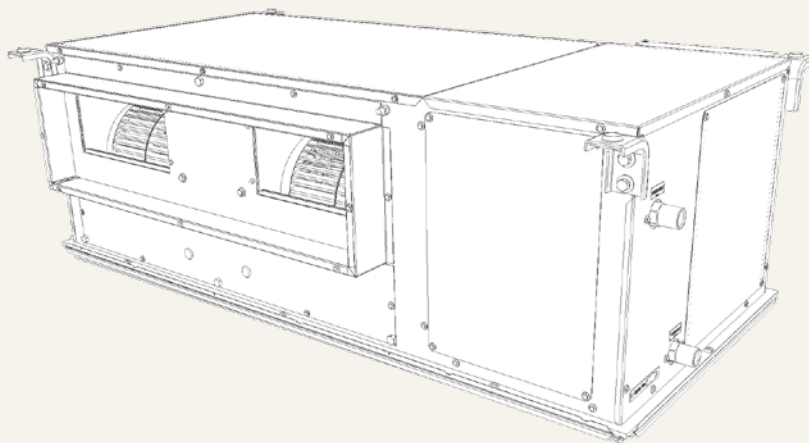

Water Cooled air conditioners

HWP 36–275 series



Applications

The HWP-K units are ideal for multi-unit installations such as high-rise office, apartments or hotel buildings, where the flexibility of individual zone control is required.

INTRODUCTION

The temperzone HWP-K Series represents a range of ducted, water sourced, packaged air conditioners designed to provide year round comfort to room occupiers.

Compact and reliable, these units can be installed above ceilings/corridors, or in other concealed spaces, saving valuable floor space and providing conditioned air direct to necessary locations.

HWP-K Series units are designed to be used with simple duct layouts. To take maximum advantage of this feature, units should be located as close to the space to be air conditioned as acoustic criteria allows. Multiple small units, utilizing minimal duct lengths, prove more economical than a single large central ducted unit.

Designed also to suit different climates, the HWP-K units are available in three versions:

1. Reverse Cycle (R)
ie Heat Pump / Cooling & Heating
2. Cooling Only with Electric Heat (CE)
3. Cooling Only (C) – not available in Australia

The standard unit is right handed, i.e. when facing the discharge side of the unit, the water connections are on the right hand side of the unit. Opposite Hand versions are also available.

In office buildings, an HWP unit system can provide the ideal off-peak system for occupied areas when the main system is not running, e.g. night time, weekends, holidays.

HWP unit systems can be applied to provide owner occupiers with individual control and billing, thus avoiding large central plant room areas, e.g. in apartment buildings.

Installing multiple reverse cycle versions enables simultaneous heating and cooling in different parts of a building.

Multiple HWP units are typically part of an overall hydronic system that incorporates some form of heat rejection equipment – usually a cooling tower or dry air cooler (radiator). Complementing the HWP Series is the temperzone ACW Series radiators – a range of closed circuit water coolers which serve as the central plant for rejecting heat collected by the HWP units. Refer to your nearest temperzone representative for further information on the ACW Series – only available in New Zealand.

Water Cooled air conditioners

HWP 36–275 series



FEATURES

Refrigerant R410A

Each unit is factory charged with refrigerant R410A, which has a zero ozone depletion potential.

Efficient

These air conditioners provide one of the most efficient forms of cooling and/or heating you can invest in, as evidenced by their high EER figures. Each unit incorporates a high efficiency scroll compressor. Heat exchange air coils use inner grooved (rifled) tube for better heat transfer.

ThermoShell® Technology

The unit includes a compact long life highly efficient water heat exchanger design with non-fouling properties.

Performance

The fan speed can be stepped (ie High/Med/Low) to match the supply air requirements.

Durable

Temperzone units have a tough galvanised steel construction. The air coil is die formed plate type epoxy coated aluminium fins mechanically bonded to high efficiency inner grooved copper tubes. Each HWP unit alone (excluding hoses) will withstand a maximum water pressure of 3200 kPa (464 psi). Condensate drain trays are insulated and powder coated for complete moisture protection. The drain tray is easily removed for inspection and cleaning.

Quiet

HWP units have bonded polyester lined compressor and fan compartments to minimise noise. Spring mounting kits are supplied with every unit to minimise the transfer of any vibration.

Safety

Units are fitted with a high pressure lockout that protects the unit in the event of water flow failure in cooling mode. Sensors protect against low air coil temperature and loss of refrigerant. Units include an anti-rapid cycle timer for compressor on/off protection.

HWP reverse cycle units also have a low refrigerant pressure sensor to protect against icing-up of the water within the unit's ThermoShell® condenser on heating mode and a water pump flow verification input to protect individual units from a loss of water flow.

Convenient lockout contactor resetting is simply achieved by turning the power to the unit off and then on again, avoiding the need to gain access to each unit if the cause is failure of central water supply.

Each compressor has internal overload protection.

The HWP reverse cycle version has a low refrigerant pressure limit and a reverse cycle change-over valve.

Insulation

Closed cell foam insulation has been used to inhibit mould growth in places where moisture could be present and provide thermal protection, eg to minimise cold tracking. Bonded polyester insulation ensures no particles are introduced into the air stream.

Insulation is foil faced and meets fire test standards AS 1530.3 (1999) and BS 476 parts 6 & 7.

Control Options

The unit's UC8 Controller can be connected to Temperzone's SAT-3, TZT-100 or other compatible room temperature controllers supplied by others. It is BMS compatible via Modbus/RS485 port with multi-unit control possible – either via digital and analogue signals or via Modbus. The UC8 can activate the water circulating pump (only when required) and/or a local water on/off valve, thus saving pump running costs. It can also control the position of a motorised water flow control valve (using 0–10V signal), so that head pressure control can be achieved and lower water temperatures can be used on cooling mode.

Water Cooled air conditioners

HWP 36–275 series



Self Diagnostics

Any faults detected are displayed on the UC8 and optional SAT-3 Wall plaque. General fault and run status output signals are available for remote indication to building management systems.

Peace of Mind

Temperzone operates a quality management system that conforms to AS/NZS ISO 9001:2008. The company's products have been selected, against worldwide competition, for use in some of the most exclusive projects – chosen because of their proven efficiency, durability, performance, reliability and value.

Electric Heating

(HWP-CE model)

Electric element/s have spiral wound stainless steel fins to give increased area and low surface temperature. They are totally enclosed within the unit and are supplied with auto (90°C) and manual (120°C) high temp. safety thermostats required to meet AS/NZS 60335.2.40 2006. A fan run-on timer for rapid heat dissipation is incorporated into the UC8 as well as a 70° fast acting temperature sensor to ensure overall safety.

ACCESSORIES (SUPPLIED)

Air Filter

Each unit is supplied with a washable synthetic fibre EU2/G2 rated filter that is integrated with the return air spigot. This filter complies with AS/NZS 1324.1:2001 for airflows up to 1000 l/s.

For ducted return air applications, filters should ideally be located in the ceiling return air grille/s and removed from the HWP unit's return air spigot, thereby improving access for cleaning.

Flexible Hoses

The HWP is supplied with two high pressure hoses (HWP 36–142: 600 mm long; HWP 172–275: 800 mm long) for water connections. The hoses have female pipe threaded nut fittings at both ends. Maximum water pressure for 600 length is 1720 kPa (250 psi); 800 length is 2070 kPa (300psi).

Spring Mounting Kit

The HWP Series Spring Mounting System, supplied with each unit, has been designed to minimise the transfer of vibration from the HWP unit into the building structure. Recommended for use in all installations.

OPTIONAL EQUIPMENT

1. temperzone SAT-3 Controller or TZZ-100 Controller
– connection cables supplied separately.
2. Condensate -Lift Pump – max. lift 800mm.

INSTALLATION

Acoustics

Shorter duct applications will require greater attention to acoustic criteria (refer page 15).

Mounting

It is recommended that HWP units be mounted using the spring mounting system supplied. This system minimises transfer of vibration into the building structure.

Positioning

When determining the installation location consideration should be given to each unit to facilitate future servicing and maintenance, e.g. room for removal of filter and access to electrics.

Condensate Drain

The condensate drain should have a slope of at least 1 in 50 and must not be piped to a level above the unit drain tray.

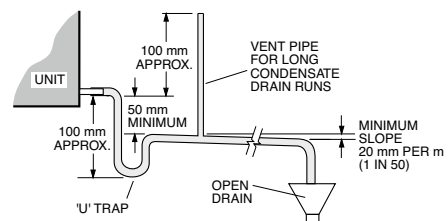

Condensate drain traps are required on the larger models, i.e. HWP 79–275.

An optional condensate lift-pump is available to remove condensate from the unit in tight installations where a well sloped drain line is not practical.

Water Cooled air conditioners

HWP 36–275 series



WATER CONNECTION

General

The HWP unit's IN and OUT water connections are male pipe threaded. The unit can be piped directly or by using two temperzone flexible high pressure water hoses (supplied) which have female pipe threaded connections at each end.

Poor quality water supply must be pre-filtered and it is essential that adequate water treatment is maintained, particularly where open cooling towers are used.

Note: It is recommended that the water supply system be fitted with a water flow switch and water flow verification circuit. These items prevent the HWP units from going into fail safe lockout status due to a loss of water flow. Failure to install the above items could require the resetting of all HWP units in the system – by breaking the power supply to each unit or by Modbus command.

Circuit Balancing Valve

It is recommended that a circuit balancing valve be fitted to maintain water flow at a constant rate. The water flow rates in litres per second (l/s), at nominal water temperature, are stated in the Specifications Table (page 21-22). The water circuit needs to be balanced to suit the design ΔT of the central water system.

The HWP unit controller will protect the refrigeration system of the unit under extreme conditions. On heating cycle it protects to ensure the evaporating temperature does not drop below freezing point for an extended period. **It is important that the leaving water temperature does not fall be low 4°C.** The entering water temperature will determine how low the water flow can be allowed to go without causing nuisance trips from this protection. Refer page 14 for flow data.

Water Circulating Pump & Flow Verification Option

In order to promote efficiency and avoid running the water circulation pump unnecessarily, the unit's UC8 Controller can be used to control the activation of the pump prior to running the compressor. After activation of the circulating pump contactor (not part of the HWP unit), the UC8 waits for the pump flow verification relay contact (PFVR) to close before energising the compressor contactor (CMC) and therefore starting the compressor (refer wiring diagram). The UC8 also de-activates the pump when the compressor stops.

Water Control Options

System designers have one of two options:

1. Water Regulating Valve Control Option

A 0-10V signal is available on output V1 for the control of a water flow control valve (optional; not supplied by temperzone); refer wiring diagram. When used, the valve is closed (0V signal) when the compressor is off. When the unit is cooling the signal will control the valve to obtain an optimum condensing temperature. When the unit is heating (reverse cycle units) the valve is directed fully open (10V signal).

OR

2. Water Shut-Off Valve Option

This will ensure the water is not flowing through the unit when it is not operational for a long period of time, thereby reducing the overall central pump power usage. The water shut-off relay on the HWP can be used to activate a water shut-off valve (supplied and fitted by others).

SAFETY FEATURES

1. HP and loss of refrigerant protection.
2. Anti-rapid cycle timer and internal overload for compressor protection.
3. Circuit breaker control circuits.
4. Electronic pressure control prevents icing up of the Thermoshell® heat exchanger during heating cycle.
5. Frost protection on cooling cycle.
6. Sensor fault indication.
7. Compressor minimum run time to ensure oil return.

ELECTRICAL

The electrical supply required (including voltage fluctuation limits) is:

HWP 36/48/59/79/98:

1 phase 230 V a.c. 50 Hz with neutral and earth.

HWP 118/142/172/192/255/275:

3 phase 400 V a.c. 50 Hz with neutral and earth.

All units are compliant to the latest MEP standards.

Water Cooled air conditioners

HWP 36–275 series



NOMENCLATURE

Example

H	W	P	7	9	C	E	K	S
Series			Size		Type			
H - Hideaway W - Water Sourced P - Packaged			Divide by 10 to get approx. nominal Capacity in kilowatts		C - Cooling only CE - Cooling only with electric heat R - Reverse cycle K - Refrigerant R410A S - Single phase power supply			

TECHNICAL SUPPORT

For more information on the manufacturer or product support information, visit the website www.temperzone.biz

Water Cooled air conditioners

SAT-3 Controller (Optional)

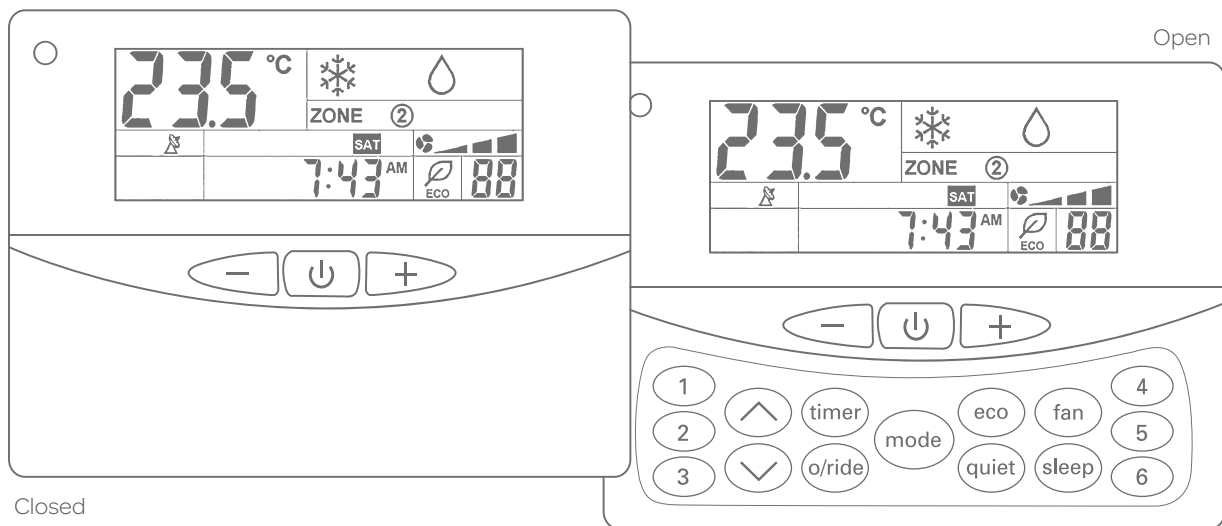

FEATURES SUMMARY

- Cool / Cool Dry / Heat / Auto Dry / Auto / Fan Only modes.
- Auto / High / Medium / Low fan speed selection. (customisable).
- Temperature setting range from 16°C – 30°C.
- LED to indicate status of the unit [Power On/Off].
- Room temperature display.
- Real time clock.
- **7 day timer** – up to two events (four start and/or stops per day)
- On demand countdown run timer, up to 9 hours.
- Auto-Restart or No Restart after power failure.
- Continuous or Intermittent selection of fan run-on in dead zone.
- Backlit screen for ease of reading; changes colour for each mode.
- Soft touch tab keys
- Battery backup (Lithium).
- **Sleep function** – improves night time comfort and saves energy.
- Audible beep to acknowledge key entry or wireless remote control.
- Low voltage control cable.
- **Colour:** white and light grey (Keypad – green and blue).

Optional:

Remote return air sensor

Note: Not backwards compatible with units using SAT-2.

TZT-100:

Refer www.temperzone.biz for information.

Water Cooled air conditioners

Performance Data



COOLING CAPACITY (KW)

T = Total Capacity (kW) HR = Heat Rejection (kW)
 S = Sensible Capacity (kW) FL = Water Flow (l/s)
 E.A.T. = Entering Air Temperature (°C)
 ○ = Nominal Capacity (kW).

Note: Capacities are **gross** and do not include allowance for fan motor heat loss. For fan motor heat loss refer to Air Handling Performance. Water flow and cooling capacity based on 5 °C water temp. difference.

Model	Coil E.A.T.		Leaving water temperature (LWT) °C D.B.																								
	Air l/s	W.B. °C	D.B. °C	25				30				35				40				45				50			
				T	S.	FL	HR	T	S.	FL	S	T	S.	FL	HR	T	S.	FL	HR	T	S.	FL	HR	T	S.	FL	HR
HWP 36	190	17	23	3.6	2.8	0.22	4.4	3.4	2.6	0.22	4.3	3.3	2.5	0.22	4.2	3.1	2.4	0.22	4.1	3.1	2.3	0.22	4.1	3.0	2.1	0.22	4.1
		19	27	3.8	2.8	0.22	4.7	3.8	2.8	0.22	4.7	3.5	2.8	0.22	4.4	3.4	2.6	0.22	4.4	3.1	2.6	0.22	4.1	3.1	2.5	0.22	4.1
		21	31	4.1	3.3	0.22	5.0	4.1	3.3	0.22	5.0	4.0	3.3	0.22	5.1	3.7	3.2	0.22	4.7	3.5	3.2	0.22	4.6	3.3	3.2	0.22	4.4
HWP 48	230	17	23	4.6	3.6	0.28	5.6	4.4	3.4	0.28	5.4	4.2	3.2	0.28	5.3	4.0	3.1	0.28	5.2	3.9	3.0	0.28	5.2	3.9	2.7	0.28	5.2
		19	27	4.9	3.6	0.28	6.0	4.8	3.6	0.28	6.0	4.4	3.6	0.28	5.6	4.3	3.4	0.28	5.6	4.0	3.3	0.28	5.2	3.9	3.3	0.28	5.2
		21	31	5.2	4.2	0.28	6.3	5.2	4.2	0.28	6.3	5.1	4.2	0.28	6.4	4.7	4.1	0.28	6.0	4.5	4.1	0.28	5.8	4.2	4.0	0.28	5.6
HWP 59	320	17	23	6.1	5.1	0.34	7.6	5.8	4.7	0.34	7.4	5.6	4.5	0.34	7.2	5.3	4.4	0.34	7.0	5.2	4.2	0.34	7.0	5.2	3.8	0.34	7.0
		19	27	6.5	5.1	0.34	8.1	6.5	5.0	0.34	8.1	5.9	5.0	0.34	7.6	5.8	4.7	0.34	7.5	5.3	4.6	0.34	7.0	5.2	4.6	0.34	7.0
		21	31	7.0	5.9	0.34	8.6	6.9	5.9	0.34	8.5	6.9	5.8	0.34	8.7	6.3	5.8	0.34	8.1	6.0	5.7	0.34	7.8	5.7	5.6	0.34	7.5
HWP 79	500	17	23	8.4	6.7	0.50	9.9	7.7	6.2	0.50	9.7	7.7	5.9	0.50	9.8	7.3	5.8	0.50	9.5	7.2	5.5	0.50	9.5	7.1	5.0	0.50	9.4
		19	27	6.7	6.7	0.50	10.6	8.6	6.6	0.50	10.6	8.1	6.6	0.50	10.2	7.9	6.2	0.50	10.2	7.3	6.2	0.50	9.5	7.2	6.0	0.50	9.5
		21	31	0.5	7.8	0.50	11.3	9.2	7.8	0.50	11.2	9.5	7.7	0.50	11.7	8.6	7.6	0.50	10.9	8.3	7.5	0.50	10.6	7.8	7.5	0.50	10.2
HWP 98	560	17	23	10.2	8.3	0.61	12.5	9.7	7.7	0.61	12.2	9.3	7.3	0.61	11.9	8.9	7.1	0.61	11.6	8.7	6.8	0.61	11.5	8.6	6.2	0.61	11.5
		19	27	11.0	8.3	0.61	13.3	10.8	8.1	0.61	13.3	9.9	8.1	0.61	12.5	9.6	7.7	0.61	12.4	8.9	7.6	0.61	11.6	8.7	7.4	0.61	11.6
		21	31	11.7	9.6	0.61	14.2	11.6	9.6	0.61	14.1	11.5	9.5	0.61	14.3	10.5	9.4	0.61	13.3	10.0	9.3	0.61	12.9	9.5	9.2	0.61	12.4
HWP 118	620	17	23	12.7	9.6	0.75	15.5	12.1	8.9	0.75	15.0	11.5	8.5	0.75	14.7	11.0	8.3	0.75	14.3	10.8	7.9	0.75	14.2	10.7	7.2	0.75	14.2
		19	27	13.6	9.7	0.75	16.4	13.4	9.5	0.75	16.4	12.2	9.5	0.75	15.4	11.9	8.9	0.75	15.4	11.0	8.8	0.75	14.3	10.8	8.7	0.75	14.3
		21	31	14.5	11.2	0.75	17.5	14.3	11.1	0.75	17.3	14.2	11.1	0.75	17.7	13.0	11.0	0.75	16.4	12.4	10.8	0.75	16.0	11.7	10.7	0.75	15.3
HWP 142	775	17	23	15.2	11.5	0.88	18.4	14.5	10.7	0.88	17.9	13.8	10.2	0.88	17.6	13.2	10.0	0.88	17.0	13.0	9.5	0.88	17.0	12.9	8.7	0.88	16.9
		19	27	16.3	11.6	0.88	19.5	16.1	11.4	0.88	19.6	14.7	11.3	0.88	18.4	14.3	10.7	0.88	18.3	13.2	10.6	0.88	17.1	13.0	10.4	0.88	17.1
		21	31	17.4	13.4	0.88	20.8	17.2	13.4	0.88	20.7	17.1	13.3	0.88	21.0	15.6	13.2	0.88	19.6	14.9	13.0	0.88	19.0	14.1	12.9	0.88	18.3
HWP 172	1015	17	23	19.1	15.4	1.06	23.1	18.2	14.3	1.06	22.4	17.4	13.6	1.06	22.0	16.6	13.3	1.06	21.3	16.4	12.7	1.06	21.3	16.2	11.6	1.06	21.2
		19	27	20.5	15.4	1.06	24.5	20.2	15.2	1.06	24.5	18.5	15.1	1.06	23.0	18.0	14.3	1.06	22.9	16.6	14.1	1.06	21.4	16.4	13.8	1.06	21.4
		21	31	21.9	17.9	1.06	26.1	21.7	17.8	1.06	25.9	21.5	17.7	1.06	26.4	19.6	17.5	1.06	24.5	18.8	17.3	1.06	23.8	17.7	17.1	1.06	22.9
HWP 192	1160	17	23	21.9	17.4	1.26	26.6	20.9	16.2	1.26	25.8	19.9	15.4	1.26	25.4	19.0	15.0	1.26	24.6	18.7	14.4	1.26	24.5	18.5	13.1	1.26	24.4
		19	27	23.4	17.5	1.26	28.2	23.1	17.2	1.26	28.3	21.2	17.1	1.26	26.5	20.6	16.2	1.26	26.5	19.0	16.0	1.26	24.7	18.7	15.6	1.26	24.7
		21	31	25.0	20.2	1.26	30.1	24.8	20.1	1.26	29.9	24.5	20.1	1.26	30.4	22.4	19.8	1.26	28.3	21.4	19.5	1.26	27.5	20.3	19.4	1.26	26.4

Water Cooled air conditioners

Performance Data



COOLING CAPACITY (KW)

- T = Total Capacity (kW). HR = Heat Rejection (kW)
 S = Sensible Capacity (kW). FL = Water Flow (l/s)
 E.A.T. = Entering Air Temperature (°C)
 ○ = Nominal Capacity (kW).

Note: Capacities are **gross** and do not include allowance for fan motor heat loss. For fan motor heat loss refer to Air Handling Performance. Water flow and cooling capacity based on 5 °C water temp. difference.

Model	Coil E.A.T.			Leaving water temperature (LWT) °C D.B.																							
	Air l/s	W.B. °C	D.B. °C	25				30				35				40				45				50			
				T	S	FL	HR	T	S	FL	S	T	S	FL	HR	T	S	FL	HR	T	S	FL	HR	T	S	FL	HR
HWP 255	1220	17	23	26.4	20.1	1.53	31.6	25.1	18.6	1.53	30.7	24.0	17.8	1.53	30.1	22.9	17.3	1.53	29.2	22.6	16.5	1.53	29.1	22.3	15.1	1.53	29.0
		19	27	28.3	20.1	1.53	33.5	27.9	19.8	1.53	33.6	25.5	19.7	1.53	31.5	24.9	18.6	1.53	31.4	22.9	18.4	1.53	29.3	22.6	18.0	1.53	29.3
		21	31	30.1	23.3	1.53	35.7	29.9	23.2	1.53	35.5	29.6	23.1	1.53	36.1	27.0	22.9	1.53	33.6	25.9	22.5	1.53	32.6	24.4	22.3	1.53	31.3
HWP 275	1400	17	23	28.8	22.0	1.63	34.4	27.1	20.4	1.63	33.4	25.9	19.5	1.63	32.8	24.7	19.0	1.63	31.8	24.3	18.1	1.63	31.7	24.1	16.5	1.63	31.6
		19	27	30.5	22.1	1.63	36.5	30.1	21.7	1.63	36.6	27.5	21.6	1.63	34.3	26.8	20.4	1.63	34.2	24.7	20.2	1.63	31.9	24.3	19.8	1.63	31.9
		21	31	32.5	25.5	1.63	38.9	32.2	25.4	1.63	38.6	31.9	25.3	1.63	39.3	29.1	25.1	1.63	36.6	27.9	24.7	1.63	35.5	26.4	24.5	1.63	34.1

Water Cooled air conditioners

Performance Data - Reverse Cycle Systems



HEATING CAPACITY (KW)

HC = Heating Capacity (kW) *

HAb = Heat Absorbed (kW)

○ = Nominal Capacity (kW).

EWT = Entering Water Temperature (°C) (Minimum required 10°C)

INPT = Compressor Input (kW)

E.A.T. = Entering Air Temperature (°C)

Model	Water Flow Rate l/s	Coil E.A.T. D.B. °C	Leaving water temperature (LWT) °C											
			12.5				15.5				18.5			
			HC	HAb.	EWT	INPT	HC	HAb.	EWT	INPT	HC	HAb.	EWT	INPT
HWP 36	0.22	18	3.5	2.6	15.4	0.9	3.7	2.8	18.6	0.9	4.0	3.0	21.8	0.9
		21	3.4	2.5	15.3	0.9	3.7	2.7	18.5	1.0	4.0	3.0	21.8	1.0
		25	3.4	2.4	15.2	1.0	3.7	2.7	18.4	1.0	3.9	2.9	21.7	1.1
HWP 48	0.28	18	4.4	3.3	15.3	1.1	4.7	3.6	18.6	1.1	5.0	3.8	21.8	1.2
		21	4.3	3.2	15.3	1.1	4.6	3.5	18.5	1.2	5.0	3.8	21.7	1.2
		25	4.3	3.1	15.2	1.2	4.6	3.4	18.4	1.3	5.0	3.6	21.6	1.3
HWP 59	0.34	18	5.2	3.7	15.1	1.5	5.5	4.0	18.3	1.6	5.9	4.3	21.5	1.6
		21	5.1	3.6	15.0	1.6	5.4	3.8	18.2	1.7	5.9	4.2	21.5	1.7
		25	5.1	3.4	14.9	1.7	5.4	3.7	18.1	1.8	5.9	4.0	21.3	1.9
HWP 79	0.50	18	8.4	6.5	15.6	1.9	9.0	7.1	18.9	2.0	9.7	7.6	22.1	2.1
		21	8.4	6.4	15.5	2.0	8.9	6.9	18.8	2.1	9.7	7.5	22.1	2.2
		25	8.4	6.2	15.5	2.2	8.9	6.7	18.7	2.3	9.6	7.2	22.0	2.4
HWP 98	0.61	18	10.6	8.2	15.7	2.4	11.3	8.9	18.9	2.4	12.2	9.6	22.2	2.6
		21	10.5	8.0	15.6	2.5	11.1	8.7	18.8	2.6	12.1	9.4	22.1	2.7
		25	10.5	7.8	15.5	2.7	11.1	8.5	18.8	2.8	12.1	9.1	22.0	2.9
HWP 118	0.75	18	11.5	8.6	15.4	2.9	12.3	9.3	18.6	3.0	13.2	10.0	21.8	3.1
		21	11.4	8.3	15.3	3.0	11.9	9.0	18.5	3.2	13.1	9.8	21.8	3.3
		25	11.3	8.1	15.2	3.3	11.9	8.8	18.4	3.4	13.0	9.5	21.7	3.6
HWP 142	0.88	18	13.9	10.6	15.4	3.3	14.9	11.5	18.6	3.4	16.0	12.4	21.9	3.6
		21	13.8	10.3	15.3	3.5	14.8	11.1	18.6	3.4	15.9	12.1	21.8	3.8
		25	13.8	10.0	15.2	3.8	14.8	10.9	18.4	3.9	15.8	11.7	21.7	4.1
HWP 172	1.06	18	15.4	11.4	15.1	4.1	16.5	12.3	18.3	4.2	17.7	13.3	21.5	4.4
		21	15.3	11.0	15.0	4.3	16.4	11.9	18.2	4.5	17.7	13.0	21.4	3.8
		25	15.3	10.6	14.9	4.6	16.4	11.6	18.1	4.9	17.6	12.5	21.3	4.1
HWP 192	1.26	18	17.4	12.6	14.9	4.9	18.7	13.6	18.1	5.1	20.0	14.7	21.3	5.3
		21	17.3	12.2	14.8	5.1	18.6	13.2	18.0	5.4	20.0	14.3	21.2	5.6
		25	17.3	11.7	14.7	5.6	18.6	12.7	17.9	5.8	19.8	13.8	21.1	6.1

Water Cooled air conditioners

Performance Data - Reverse Cycle Systems



HEATING CAPACITY (KW)

HC = Heating Capacity (kW) *

HAb = Heat Absorbed (kW)

○ = Nominal Capacity (kW).

EWT = Entering Water Temperature (°C) (Minimum required 10°C)

INPT = Compressor Input (kW)

E.A.T. = Entering Air Temperature (°C)

Model	Water Flow Rate l/s	Coil E.A.T. D.B. °C	Leaving water temperature (LWT) °C											
			12.5				15.5				18.5			
			HC	HAb.	EWT	INPT	HC	HAb.	EWT	INPT	HC	HAb.	EWT	INPT
HWP 255	1.53	18	21.8	16.4	15.1	5.4	23.4	17.7	18.3	5.6	25.1	19.2	21.5	5.9
		21	21.7	15.9	15.0	5.7	23.2	17.2	18.2	6.0	25.0	18.7	21.4	6.3
		25	21.6	15.4	14.9	6.2	23.2	16.7	18.2	6.5	24.8	18.1	21.3	6.8
HWP 275	1.63	18	23.0	17.2	15.0	5.9	24.7	18.6	18.2	6.1	26.5	20.1	21.4	6.4
		21	22.9	16.7	14.9	6.2	24.5	18.0	18.1	6.5	26.4	19.6	21.4	6.8
		25	22.8	16.1	14.9	6.7	24.5	17.5	18.1	7.0	26.2	18.9	21.3	7.3

Water Cooled air conditioners

Performance Data



AIR HANDLING

Airflows are for a dry coil. Reduce airflow by 10% in high moisture removal conditions. In a free blow application, beware of exceeding fan motor's full load amp limit. Refer page 13 for filter losses. **Air flows given are for HWP units without filter installed.**

HWP 36

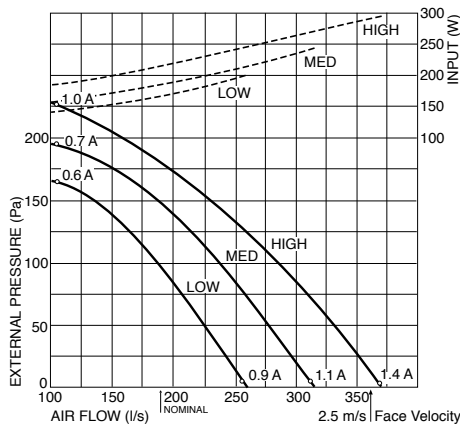

HWP 48

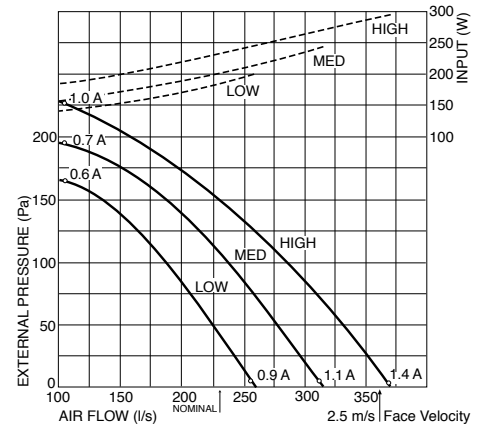

HWP 59

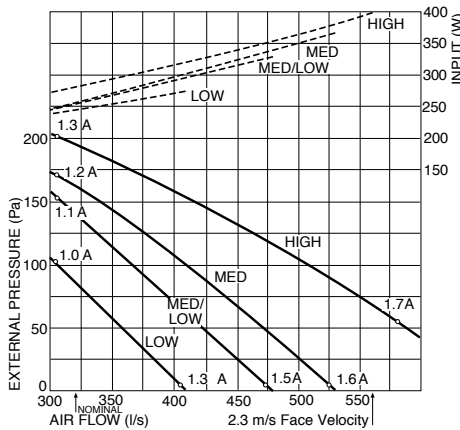

HWP 79

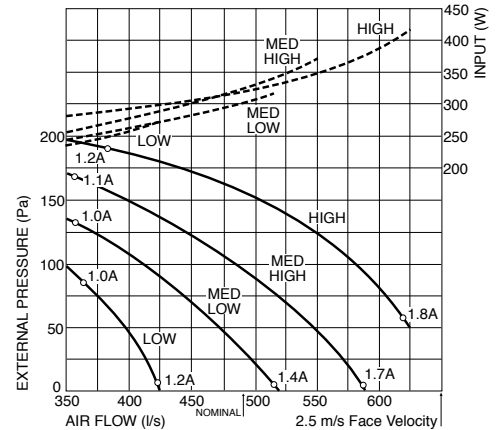

HWP 98

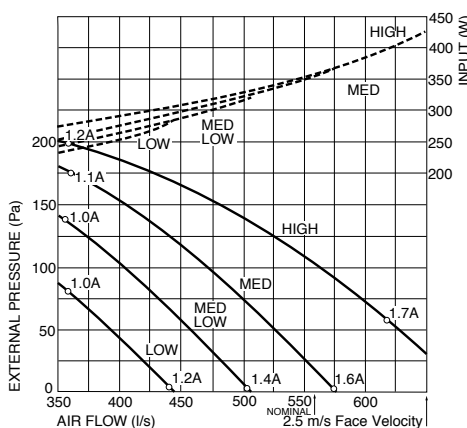

HWP 118

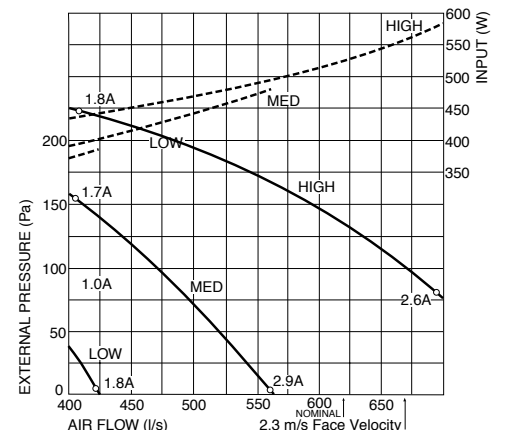

Water Cooled air conditioners

Performance Data



AIR HANDLING (CONT'D)

Airflows are for a dry coil. Reduce airflow by 10% in high moisture removal conditions. In a free blow application, beware of exceeding fan motor's full load amp limit. Refer table below for filter losses. **Air flows given are for HWP units without filter installed.**

HWP 142

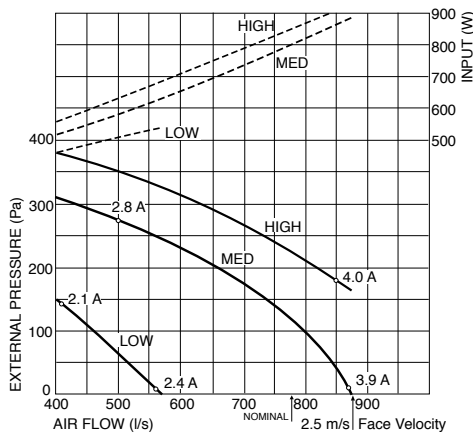

HWP 172

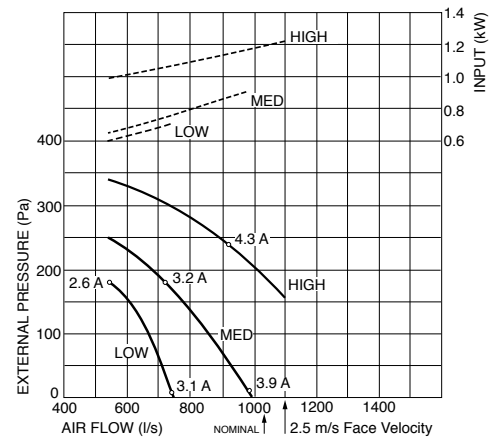

HWP 192

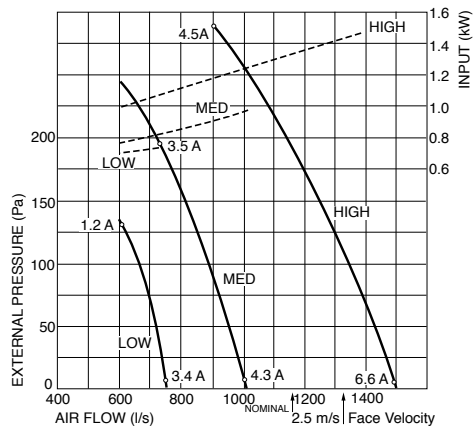

HWP 255

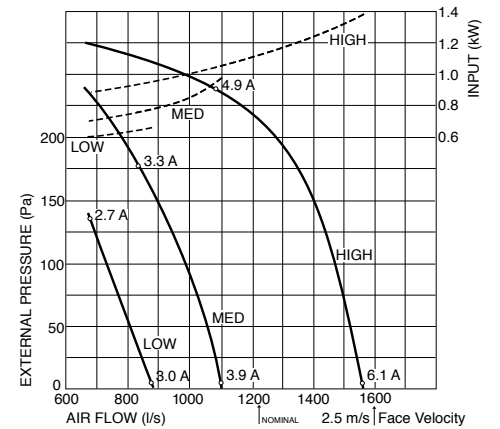

HWP 275

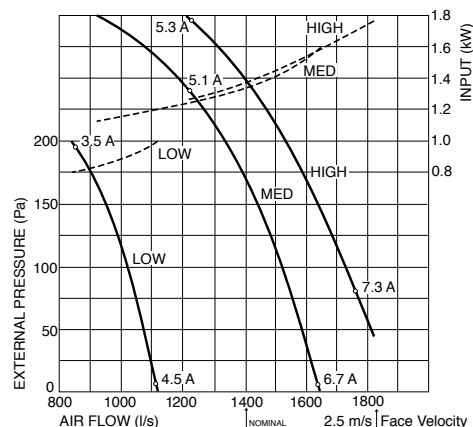

Note

1. In tropical (high humidity) conditions care must be taken to select an air flow which gives a suitable coil face air velocity, to prevent water carry over.
2. Applications using full or high proportions of fresh air should be referred to temperzone engineering office to establish the correct selection of units.

Pressure Drop - EU2/G2 rated filter media (clean):

Coil Face Velocity (m/s)	1.5	2.0	2.5
Pressure Loss (Pa)	15	25	40

Water Cooled air conditioners

Performance Data



WATER FLOW VS PRESSURE DROP

The chart below shows Water Flows and Pressure Drop at varying water temperature differences.

Nominal water flow is at a Water Temperature difference of 5K. The reduced water flows shown below have minimal effect on performance.

Model:	HWP36		HWP48		HWP59		HWP79		HWP98	
THR	4.4		5.6		7.6		10.2		12.5	
Water Temp Difference K	Water Flow l/s	Press Drop kPa	Water Flow l/s	Press Drop kPa	Water Flow l/s	Press Drop kPa	Water Flow l/s	Press Drop kPa	Water Flow l/s	Press Drop kPa
5.0	0.22	27.6	0.28	27.6	0.34	41.0	0.50	70.0	0.61	41.0
5.5	0.19	20.9	0.24	22.8	0.33	38.8	0.44	55.1	0.54	28.7
6.0	0.18	17.6	0.22	19.2	0.30	32.6	0.41	46.3	0.50	24.1
6.5	0.16	15.0	0.21	16.3	0.28	27.8	0.38	39.5	0.46	20.5
7.0	0.15	12.9	0.19	14.1	0.26	23.9	0.35	34.0	0.43	17.7
7.5	0.14	11.2	0.18	12.3	0.24	20.8	0.33	29.6	0.40	15.4
Min. water flow	0.06	2.1	0.07	7.5	0.09	2.9	0.14	5.5	0.18	3.1

Model:	HWP118		HWP142		HWP172		HWP192		HWP255		HWP275	
THR	15.4		18.4		23.0		26.5		31.5		34.3	
Water Temp Difference K	Water Flow l/s	Press Drop kPa	Water Flow l/s	Press Drop kPa	Water Flow l/s	Press Drop kPa	Water Flow l/s	Press Drop kPa	Water Flow l/s	Press Drop kPa	Water Flow l/s	Press Drop kPa
5.0	0.75	55.0	0.88	69.0	1.06	83.0	1.26	34.0	1.53	48.30	1.63	55.20
5.5	0.67	43.9	0.80	57.1	1.00	74.0	1.16	28.5	1.40	40.48	1.49	46.25
6.0	0.61	36.9	0.73	48.0	0.92	62.1	1.06	24.1	1.28	34.01	1.37	38.86
6.5	0.57	31.4	0.68	40.9	0.85	53.0	0.98	20.5	1.19	28.98	1.26	33.11
7.0	0.53	27.1	0.63	35.2	0.79	45.6	0.91	17.7	1.10	24.99	1.17	28.55
7.5	0.49	23.6	0.59	30.7	0.73	39.8	0.85	15.4	1.03	21.77	1.09	24.87
Min. water flow	0.21	4.3	0.24	5.1	0.30	6.7	0.35	2.6	0.43	3.82	0.46	4.40

THR = Total Heat Rejection (kW)

Water Cooled air conditioners

Performance Data



SOUND LEVELS

Sound Power Levels (SWL)

Test Conditions:

SPL measured to JIS 8616 (1m from source in an anechoic chamber)

SUPPLY AIR OUTLET

Model	FAN SPEED	SOUND PRESSURE LEVEL SPL dB(A)	SOUND POWER LEVEL SWL dB(A)	OCTAVE BAND FREQUENCY Hz					
				125	250	500	1K	2K	4K
				SOUND POWER LEVELS (SWL) dB					
HWP 36	HIGH	50	61	64	62	56	56	53	49
	MED	47	58	62	58	54	53	49	46
	LOW	43	54	59	55	50	49	45	42
HWP 48	HIGH	50	61	64	62	56	56	53	49
	MED	47	58	62	58	54	53	49	46
	LOW	43	54	59	55	50	49	45	42
HWP 59	HIGH	55	66	67	63	62	61	59	54
	MED	52	63	66	61	59	59	56	50
	MED/LOW	50	61	64	58	57	57	54	48
	LOW	47	58	63	56	54	54	51	45
HWP 79	HIGH	55	66	67	63	62	61	59	54
	MED	52	63	66	61	59	59	56	50
	MED/LOW	50	61	64	58	57	57	54	48
	LOW	47	58	63	56	54	54	51	45
HWP 98	HIGH	55	66	67	63	62	61	59	54
	MED	52	63	66	61	59	59	56	50
	MED/LOW	50	61	64	58	57	57	54	48
	LOW	47	58	63	56	54	54	51	45
HWP 118	HIGH	58	69	67	65	65	65	62	61
	MED	52	63	62	59	59	59	55	53
	LOW	47	58	58	54	55	54	49	46
HWP 142	HIGH	60	71	70	68	67	66	64	62
	MED	57	68	67	65	65	62	61	58
	LOW	48	59	59	56	59	52	50	45
HWP 172	HIGH	62	73	70	70	69	69	66	64
	MED	57	68	66	65	65	64	60	57
	LOW	52	63	62	61	62	57	55	51
HWP 192	HIGH	61	72	72	70	68	67	64	62
	MED	54	65	66	62	63	60	57	54
	LOW	50	61	60	57	61	54	50	45

Water Cooled air conditioners

Performance Data



SOUND LEVELS

Sound Power Levels (SWL)

Test Conditions:

SPL measured to JIS 8616 (1m from source in an anechoic chamber)

SUPPLY AIR OUTLET

Model	FAN SPEED	SOUND PRESSURE LEVEL SPL dB(A)	SOUND POWER LEVEL SWL dB(A)	OCTAVE BAND FREQUENCY Hz					
				125	250	500	1K	2K	4K
				SOUND POWER LEVELS (SWL) dB					
HWP 255	HIGH	64	75	76	72	70	70	67	66
	MED	56	67	70	64	65	61	59	56
	LOW	50	61	65	58	60	55	52	48
HWP 275	HIGH	67	78	77	75	73	74	70	69
	MED	64	75	76	73	71	71	68	66
	LOW	58	69	72	65	66	64	60	58

Water Cooled air conditioners

Performance Data



SUPPLY AIR OUTLET + INSULATED DUCT

Model	FAN SPEED	SOUND PRESSURE LEVEL SPL dB(A)	SOUND POWER LEVEL SWL dB(A)	OCTAVE BAND FREQUENCY Hz					
				125	250	500	1K	2K	4K
				SOUND POWER LEVELS (SWL) dB					
HWP 36	HIGH	41	52	54	52	46	46	43	39
	MED	39	49	53	49	45	44	40	37
	LOW	36	45	52	43	43	42	35	35
HWP 48	HIGH	41	52	54	52	46	46	43	39
	MED	39	49	53	49	45	44	40	37
	LOW	36	45	52	43	43	42	35	35
HWP 59	HIGH	46	57	57	53	52	51	49	44
	MED	44	54	57	52	50	50	47	41
	MED/LOW	43	52	57	51	50	50	47	41
	LOW	41	49	57	50	48	48	45	39
HWP 79	HIGH	46	57	57	53	52	51	49	44
	MED	44	54	57	52	50	50	47	41
	MED/LOW	43	52	57	51	50	50	47	41
	LOW	41	49	57	50	48	48	45	39
HWP 98	HIGH	46	57	57	53	52	51	49	44
	MED	44	54	57	52	50	50	47	41
	MED/LOW	43	52	57	51	50	50	47	41
	LOW	41	49	57	50	48	48	45	39
HWP 118	HIGH	49	60	57	55	55	55	52	51
	MED	44	54	53	50	50	50	46	44
	LOW	41	49	52	48	49	48	43	40
HWP 142	HIGH	51	62	60	58	57	56	54	52
	MED	49	59	58	56	56	53	52	49
	LOW	42	50	53	50	53	46	44	39
HWP 172	HIGH	53	64	60	60	59	59	56	54
	MED	48	59	57	56	56	55	51	48
	LOW	46	57	56	55	56	51	49	45
HWP 192	HIGH	51	62	62	60	58	57	54	52
	MED	45	56	57	53	54	51	48	45
	LOW	44	55	54	51	55	48	44	39

Water Cooled air conditioners

Performance Data



SUPPLY AIR OUTLET + INSULATED DUCT

Model	FAN SPEED	SOUND PRESSURE LEVEL SPL dB(A)	SOUND POWER LEVEL SWL dB(A)	OCTAVE BAND FREQUENCY Hz					
				125	250	500	1K	2K	4K
				SOUND POWER LEVELS (SWL) dB					
HWP 255	HIGH	54	65	66	62	60	60	57	55
	MED	47	58	61	55	56	52	50	47
	LOW	44	55	59	52	53	49	46	42
HWP 275	HIGH	57	68	67	64	63	62	59	58
	MED	55	66	67	64	62	62	59	57
	LOW	52	63	66	59	60	58	54	52

Water Cooled air conditioners

Performance Data



CASE BREAKOUT + RETURN AIR

Model	FAN SPEED	SOUND PRESSURE LEVEL SPL dB(A)	SOUND POWER LEVEL SWL dB(A)	OCTAVE BAND FREQUENCY Hz					
				125	250	500	1K	2K	4K
				SOUND POWER LEVELS (SWL) dB					
HWP 36	HIGH	50	61	66	64	56	54	52	48
	MED	46	57	64	61	53	50	48	45
	LOW	43	54	61	57	50	46	44	40
HWP 48	HIGH	50	61	66	64	56	54	52	48
	MED	46	57	64	61	53	50	48	45
	LOW	43	54	61	57	50	46	44	40
HWP 59	HIGH	52	63	68	63	59	59	56	49
	MED	49	60	66	60	56	55	53	44
	MED/LOW	47	58	65	57	55	53	50	41
	LOW	45	56	63	55	53	51	48	38
HWP 79	HIGH	52	63	68	63	59	59	56	49
	MED	49	60	66	60	56	55	53	44
	MED/LOW	47	58	65	57	55	53	50	41
	LOW	45	56	63	55	53	51	48	38
HWP 98	HIGH	52	63	68	63	59	59	56	49
	MED	49	60	66	60	56	55	53	44
	MED/LOW	47	58	65	57	55	53	50	41
	LOW	45	56	63	55	53	51	48	38
HWP 118	HIGH	54	65	68	63	62	60	57	53
	MED	49	60	65	58	58	55	51	46
	LOW	47	58	63	54	57	52	47	42
HWP 142	HIGH	56	67	69	67	65	62	58	54
	MED	53	64	67	64	62	58	54	50
	LOW	47	58	62	57	59	51	47	42
HWP 172	HIGH	61	72	76	73	68	67	64	60
	MED	56	67	72	67	64	61	58	55
	LOW	53	64	69	63	63	58	54	50
HWP 192	HIGH	57	68	73	69	64	63	61	57
	MED	52	63	66	62	60	58	54	50
	LOW	50	61	61	57	59	53	50	54

Water Cooled air conditioners

Performance Data



CASE BREAKOUT + RETURN AIR

Model	FAN SPEED	SOUND PRESSURE LEVEL SPL dB(A)	SOUND POWER LEVEL SWL dB(A)	OCTAVE BAND FREQUENCY Hz					
				125	250	500	1K	2K	4K
				SOUND POWER LEVELS (SWL) dB					
HWP 255	HIGH	59	70	75	69	66	64	61	59
	MED	52	63	70	62	62	57	54	50
	LOW	49	60	66	58	60	52	49	46
HWP 275	HIGH	62	73	78	72	70	69	64	62
	MED	60	71	76	70	68	66	62	59
	LOW	54	65	71	63	64	59	55	51

Water Cooled air conditioners

Performance Data



SOUND PRESSURE LEVELS (SPL) WITHIN A ROOM

Deduct the room absorption effect below from Sound Power Levels (SWL) to obtain Sound Pressure Levels within a room.

Note: Occupant at least 1.5 m from sound source.

Room type	OCTAVE BAND FREQUENCY Hz					
	125	250	500	1K	2K	4K
Soft	4	8	11	11	11	11
Medium	3	7	8	9	9	9
Hard	0	1	3	4	4	5

RECOMMENDATIONS FOR NOISE ISOLATION

Particularly for high static installations:

1. Avoid installing units, with non-ducted return air, directly above spaces where noise is critical.
2. Use flexible connections between unit and rigid ducting.
3. Use generously sized acoustically lined ducts.
4. If generous duct size is not possible, use turning vanes on bends to reduce air turbulence (regenerated noise).
5. Use 90° bends in ducting to significantly assist in noise reduction.

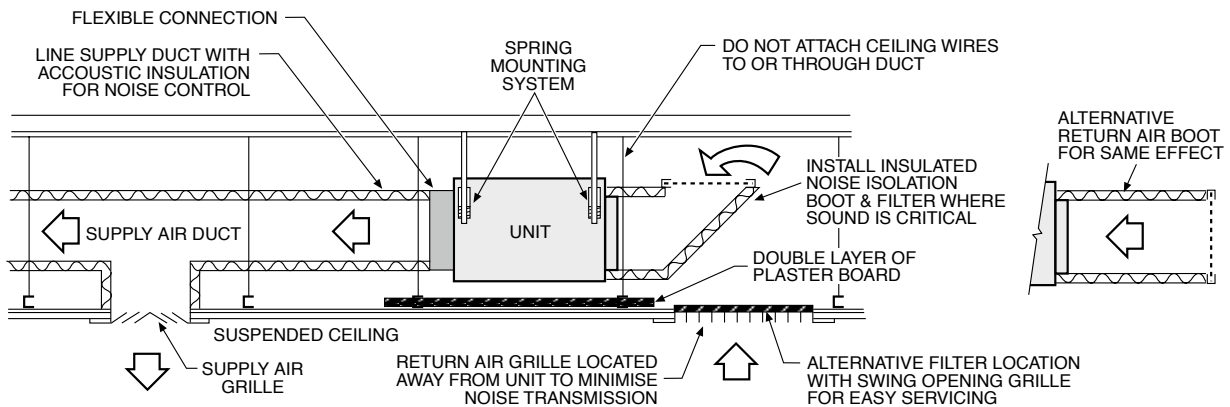
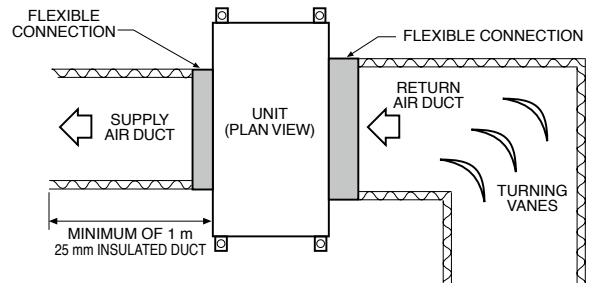

Water Cooled air conditioners

Dimensions (mm)



HWP 36-98

Model	A	B	C	D	D1	E	E1	F	G	H	J	K	L	M	N	O	P	Q	R	S	T
HWP 36	928	355	788	477	451	275	249	517	270	676	864	92	72	34	69	37	180	105	65	91	1/2"
HWP 48	928	355	788	477	451	275	249	517	270	676	864	92	72	34	69	37	180	108	65	91	1/2"
HWP 59	1255	355	788	803	778	275	249	844	270	675	1191	92	72	34	69	37	180	108	112	91	1/2"
HWP 79	1213	415	721	737	711	202	176	697	334	612	1146	72	92	47	67	28	230	112	141	41	3/4"
HWP 98	1213	415	721	737	711	202	176	697	334	612	1146	72	92	47	67	28	220	120	129	89	3/4"

Standard Hand model shown here; refer Specifications sheet for Opposite Hand model.

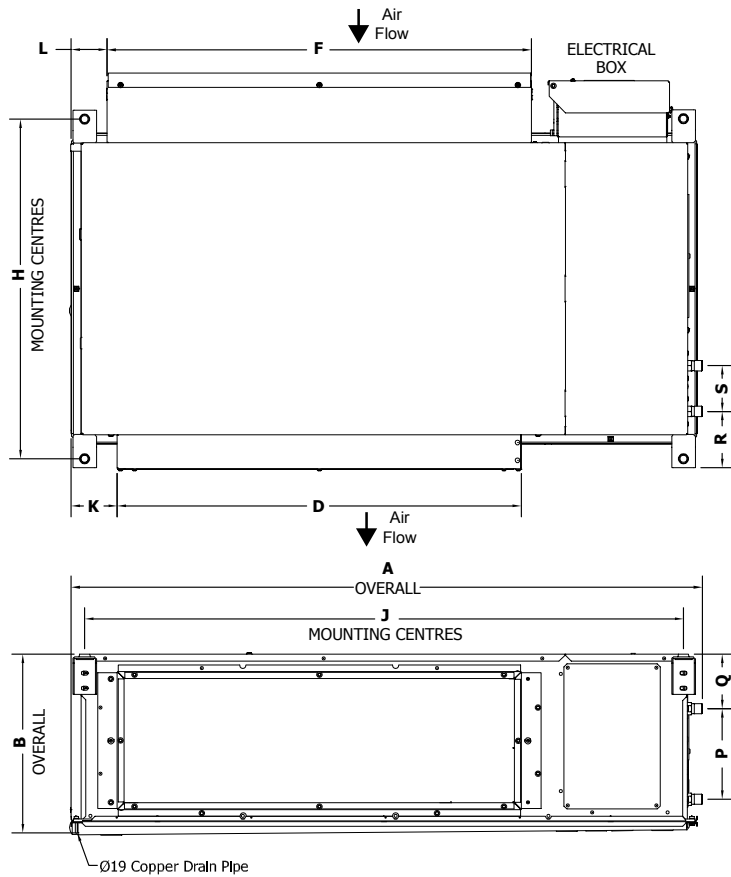
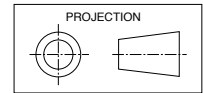

Filter access is via either side of the return air spigot

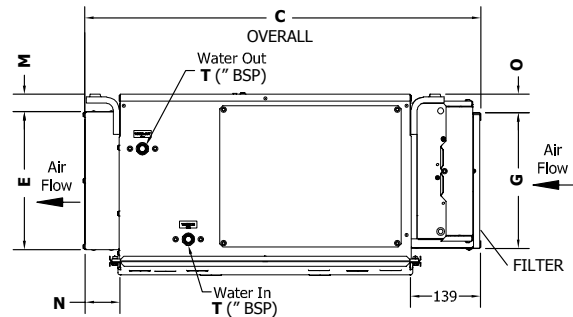
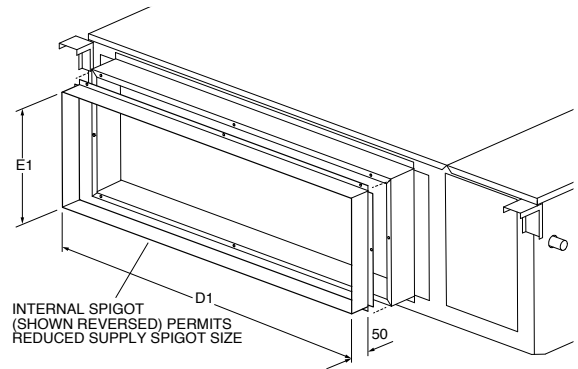

NOT TO SCALE

Materials and specifications are subject to change without notice due to the manufacturer's ongoing research and development programme.

Water Cooled air conditioners

Dimensions (mm)



HWP 118-275

Model	A	B	C	D	D1	E	E1	F	G	H	J	K	L	M	N	O	P	Q	R	S	T
HWP 118	1283	425	721	807	781	247	221	766	334	612	1216	72	92	47	67	38	220	130	129	89	3/4"
HWP 142	1283	507	771	807	781	262	237	767	410	662	1216	72	92	52	67	43	220	212	129	89	3/4"
HWP 172	1513	507	771	1007	981	262	237	967	410	662	1441	72	92	52	67	43	230	204	115	207	1"
HWP 192	1763	507	771	1207	1181	262	237	1167	410	662	1691	72	92	52	67	43	220	202	143	115	1"
HWP 255	1998	507	771	1442	1416	262	237	1402	410	662	1926	72	92	79	67	43	220	202	143	115	1"
HWP 275	2198	507	771	1642	1616	262	237	1602	410	662	2126	72	92	79	67	43	220	202	143	115	1"

Standard Hand model shown here; refer Specifications sheet for Opposite Hand model.

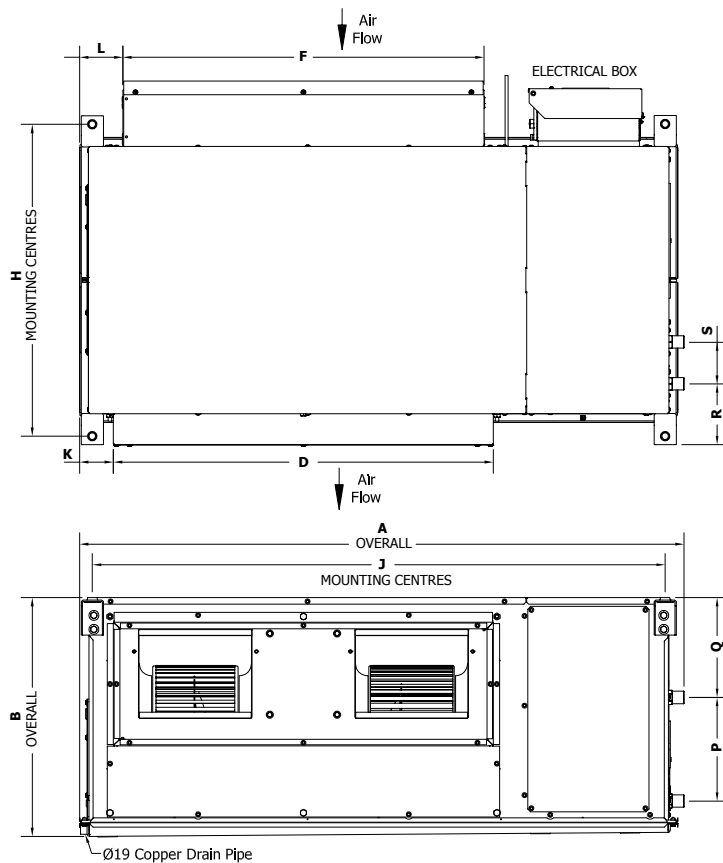
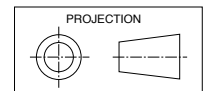

Filter access is via either side of the return air spigot

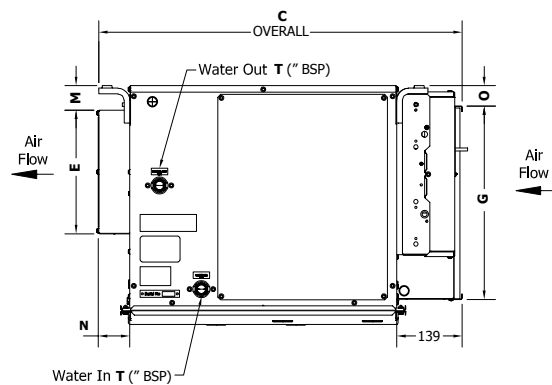
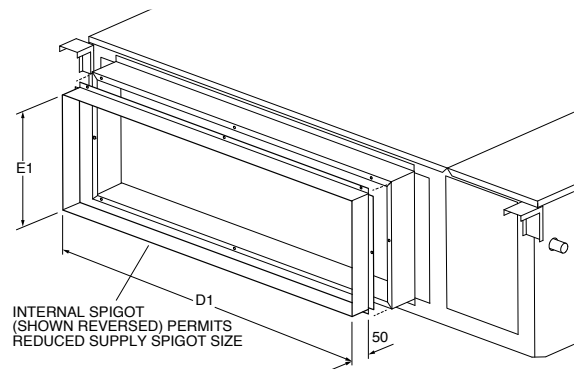

NOT TO SCALE

Materials and specifications are subject to change without notice due to the manufacturer's ongoing research and development programme.

Water Cooled air conditioners

Specifications



Model	HWP 36	HWP 48	HWP 59	HWP 79	HWP 98
Nominal Cooling Capacity * ¹ kW	3.5	4.4	5.9	8.1	9.9
Net Cooling Capacity (MEPS) kW	3.4	4.3	5.8	7.9	9.8
EER / AEER (cooling) * ⁸	3.64 / 3.61	3.64 / 3.62	3.61 / 3.60	3.71 / 3.70	3.77 / 3.76
Heating Capacity * ² kW	3.6	4.6	5.4	8.9	11.1
COP / ACOP (heating)	3.82 / 3.79	3.66 / 3.64	3.62 / 3.61	4.18 / 4.16	4.22 / 4.21
Electric Heat Option HWP-CE kW	2	2	3	4	4
Air Flow * ³ l/s	190	230	320	500	560
Power Source * ⁴	1 phase 230V a.c. 50 Hz				
HWP*R or *C version					
Running Current * ¹ A	4.2	5.2	7.6	9.1	11.5
Max. Running Current A	6.2	8.1	11.2	13.1	16.3
HWP*CE version					
Running Current * ¹ A	9.4	9.5	14.1	18.8	19.1
Max. Running Current A	10.1	10.1	14.9	19.2	19.2
Refrigerant	R410A				
Nominal Water Flow * ⁵ l/s	0.22	0.28	0.34	0.50	0.61
Minimum Water Flow * ⁶ l/s	0.06	0.07	0.09	0.14	0.18
Water Coil Pressure Drop* ⁷ kPa (psi)	27.6 (4)	27.6 (4)	41 (6)	70 (10)	41 (6)
Unit Controller	UC8				
Filter (EU2/G2 rated)	supplied				
Weight (net) kg	70	70	85	102	112

*¹ Nominal Cooling Capacity at AS/NZS 3823.1.3 conditions:

Entering Water Temperature 30°C;
Entering Air Temperature 27°C D.B., 19°C W.B.

*² Heating Capacity (HWP*R version only) at AS/NZS 3823.1.3 conditions:

Entering Water Temperature 21°C;
Entering Air Temperature 21°C D.B.

*³ Air flows at nominal conditions above.

*⁴ Voltage fluctuation limits: Single phase systems 200–252 V; Three phase systems 342–436 V

*⁵ Nominal water flow at EWT - LWT = 5k.

*⁶ At nominal Entering Water Temperature: 30°C on cooling, 21°C on heating.

*⁷ At nominal water flow.

*⁸ HWP-R version in Cooling mode.

Water Cooled air conditioners

Specifications



Model	HWP118	HWP142	HWP172	HWP192	HWP255	HWP275
Nominal Cooling Capacity * ¹ kW	12.2	14.7	18.5	21.2	25.5	27.5
Net Cooling Capacity (MEPS) kW	11.9	14.1	17.4	19.9	25.0	27.0
EER / AEER (cooling)	3.84 / 3.83	3.80 / 3.79	4.24 / 4.22	4.11 / 4.09	4.50 / 4.49	4.32 / 4.31
Heating Capacity * ² kW	11.9	14.8	16.4	18.6	23.2	24.5
COP / ACOP (rev. cycle heating)	3.80 / 3.79	4.10 / 4.09	4.10 / 4.09	4.23 / 4.21	4.45 / 4.44	4.21 / 4.21
Electric Heat Option HWP*CE kW	6	6	9	9	12	12
Air Flow * ³ l/s	620	775	1015	1160	1220	1400
Power Source * ⁴	3 phase 400V					
HWP*R or *C version						
Running Current * ¹ A	6.1/3.7/4.2	7.9/4.6/4.5	10.2/6.0/5.9	12/7/7	13.5/8.5/8	15/9.5/9.5
Max. Running Current A	8.9/6.3/6.3	11.1/7.2/7.2	13.1/8.8/8.5	16/10.8/10.8	18.5/13/13	21/13.5/13
HWP*CE version						
Running Current (heating) A	2.6/13/13	3.5/13/13	17.8/13/13	18.6/13/13	23/17.5/17.5	24/17.5/17.5
Max. Running Current A	8.9/13/13	12/13/13	18.0/13/13	19.0/13/13	24/17.5/17.5	25/17.5/17.5
Refrigerant	R410A					
Nominal Water Flow * ⁵ l/s	0.75	0.88	1.06	1.26	1.53	1.63
Minimum Water Flow * ⁶ l/s	0.21	0.24	0.30	0.35	0.42	0.46
Water Coil Pressure Drop* ⁷ kPa (psi)	55 (8)	69 (10)	83 (12)	34 (5)	48 (7)	55 (8)
Unit Controller	UC8					
Filter (EU2/G2 rated)	supplied					
Weight (net) kg	117	141	153	177	190	199

*¹Nominal Cooling Capacity at AS/NZS 3823.1.3 conditions:

Entering Water Temperature 30°C;
Entering Air Temperature 27°C D.B., 19°C W.B.

*²Heating Capacity (HWP*R version only) at AS/NZS 3823.1.3 conditions:

Entering Water Temperature 21°C;
Entering Air Temperature 21°C D.B.

*³Air flows at nominal conditions above.

*⁴ Voltage fluctuation limits: Single phase systems 200–252 V; Three phase systems 342–436 V

*⁵Nominal water flow at EWT - LWT = 5k.

*⁶At nominal Entering Water Temperature: 30°C on cooling, 21°C on heating.

*⁷At nominal water flow.

*⁸HWP-R version in Cooling mode.



www.temperzone.biz

AUCKLAND

Head Office

38 Tidal Rd, Mangere, N.Z.
Private Bag 93303, Otahuhu,
NEW ZEALAND.

Email sales@temperzone.co.nz

Phone (09) 279 5250

Fax (09) 275 5637

SYDNEY

Head Office

14 Carnegie Place, Blacktown,
NSW 2148
PO Box 8064, Seven Hills West,
NSW 2147, AUSTRALIA.

Email sales@temperzone.com.au

Phone (02) 8822 - 5700

Fax (02) 8822 - 5711

NEWCASTLE

Phone (02) 4962 - 1155

Fax (02) 4961 - 5101

TOWNSVILLE

Phone 1800 897 253

Fax (07) 3308 - 8330

WELLINGTON

Phone (04) 569 3262

Fax (04) 566 6249

ADELAIDE

Phone (08) 8115 - 2111

Fax (08) 8115 - 2118

LAUNCESTON

Phone (03) 6331 - 4209

Fax (03) 6333 - 0224

CHRISTCHURCH

Phone (03) 379 3216

Fax (03) 379 5956

MELBOURNE

Phone (03) 8769 - 7600

Fax (03) 8769 - 7601

JAKARTA

Phone +62 (21) 2963 4983

Fax +62 (21) 2963 4984

BRISBANE

Phone (07) 3308 - 8333

Fax (07) 3308 - 8330

SINGAPORE

Phone +65 6733 4292

Fax +65 6235 7180

PERTH

Phone (08) 6399 - 5900

Fax (08) 6399 - 5932

SHANGHAI

Phone +86 (21) 5648 2078



Available from